

PART NO.	DIM. "A" ±.015(0.4)
CRLCBSR-3-01	3/16 (4.8)
CRLCBSR-4-01	1/4 (6.4)
CRLCBSR-5-01	5/16 (8.0)
CRLCBSR-6-01	3/8 (9.5)
CRLCBSR-8-01	1/2 (12.7)
CRLCBSR-12-01	3/4 (19.0)

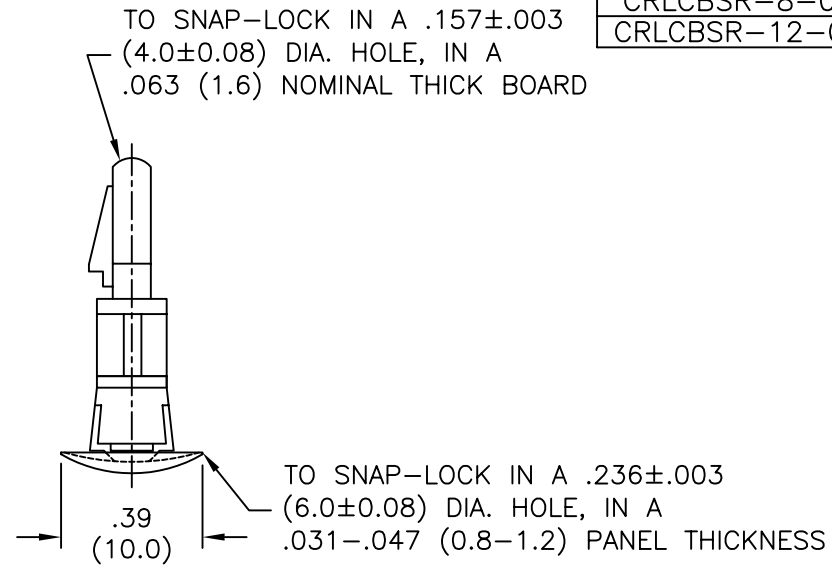
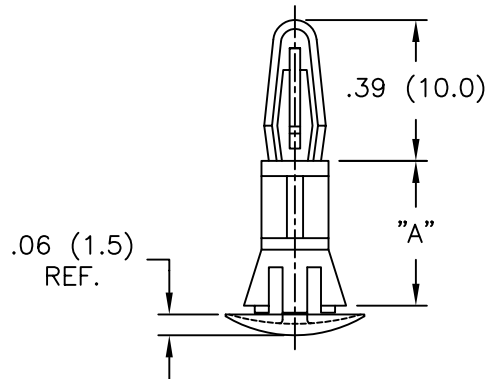

NOTES:

1. MATERIAL: NYLON 6/6 (RMS-01).
FLAME RETARDANT, NYLON (RMS-19),
AVAILABLE BY SPECIAL ORDER ONLY.
TO ORDER, REPLACE "-01" WITH "-19"
2. MATERIAL: NYLON 4/6, HEAT STABILIZED, (RMS-109)
AVAILABLE BY SPECIAL ORDER ONLY.
TO ORDER, REPLACE "-01" WITH "-109".
3. COLOR: NATURAL.
BLACK, AVAILABLE BY SPECIAL ORDER ONLY.
TO ORDER, ADD "-B" TO PART NO.

F	ADDED NOTE 2 (RMS-109) BY SPECIAL ORDER	SM 06.06.02	TITLE: CUPPED REVERSE LOCKING CBS, ROUND HOLE	DWG IN IN (MM)	
E	UPDATED NOTES AND CHANGED FILE NO.	SM 05.08.02			
D	DIM. TO S-L IN .24 (6.0)... ADDED; TABLE REDUCED; UL NOTES ADDED	PB 07.10.95	TOLERANCES UNLESS NOTED .XX=±.010 .XXX=±.005 FRAC=1/64 ANG=1°	FINAL	
C	DIMS IN CHASSIS THKNS PUT TO 3 PLACES	PB 11.23.94	FILE # CRLCBSR	DWN: P.B.	APP:
B	CONVERTED TO ACAD; DIM "A" WAS .411	PB 07.29.94	MAT'L: SEE NOTES	DT: 07-29-94	DT:
A	COMPLETE REDRAW, .40 WAS .39, .06 WAS .07, RMS-01 WAS RMS-48	RT 03.10.94	RE: RICHCO, INC.	RICHCO INC. PO BOX 804238, CHICAGO, 60680 (773) 539-4060	
REV	DESCRIPTION	ENGR DATE		PART #	PRINT TYPE
				SEE TABLE	CA